

INCH serration

- LARGE THROUGH HOLE
- 3 jaws

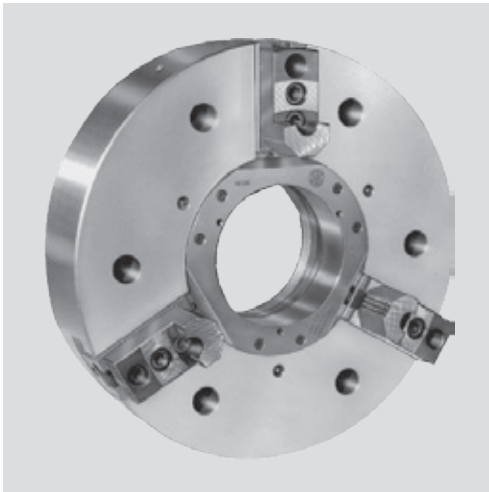

### Application/customer benefits

- For open center or partial open center clamping
- Large through-hole

**BH-D:** Master jaws with INCH serration 3/32" x 90°

### Technical features

- Gripping force transmission via wedge hook

### Standard equipment

- 3 jaw chuck
- 1 set T-nuts with bolts
- 1 set soft top jaws
- Blank ring-nut
- Mounting bolts
- Grease gun

### Ordering example

- 3 jaw chuck BH-D 500/A15
- or
- 3 jaw chuck BH-D 800/Z520

## Actual gripping force diagram

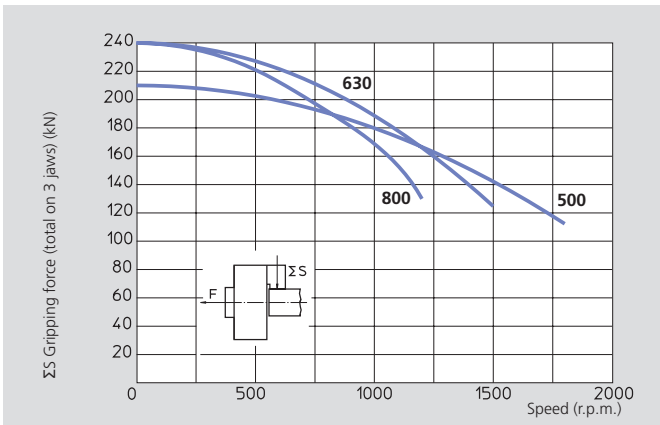

The data in the diagram refer to 3-jaw-chucks, newly maintained according to their service manuals using SMW-AUTOBLOK K05 grease. The static and dynamic gripping forces have been measured using standard soft top jaws, placed in a position not exceeding the outer diameter of the chuck.

#### ⚠ Safety advice/danger of damage:

When using taller/heavier jaws and/or clamping on a bigger diameter reduce draw pull/rotating speed accordingly.

## Technical data

SMW-AUTOBLOK Type		BH-D 500	BH-D 630	BH-D 800
<b>Number of jaws</b>		<b>3</b>	<b>3</b>	<b>3</b>
<b>Through-hole</b>	mm	180	230	230
<b>Radial jaw stroke</b>	mm	6.5	9	9
<b>Axial piston stroke</b>	mm	31	34	34
<b>Max. draw pull*</b>	kN	70	100	100
<b>Max. gripping force*</b>	kN	210	240	240
<b>Max. speed</b>	r.p.m.	1800	1500	1200
<b>Weight (without top jaws)</b>	kg	140	280	530
<b>Moment of inertia</b>	kg·m <sup>2</sup>	5	16	47
<b>Recommended actuating cylinders</b>		<b>SIN-S 150/200</b> <b>VSG 450-165</b>	<b>SIN-S 150/200</b> <b>VSG 550-205</b>	<b>SIN-S 150/200</b> <b>VSG 550-205</b>

\* For internal clamping reduce the draw pull by 30 %



Page 324

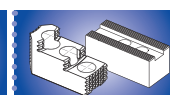

Page 326

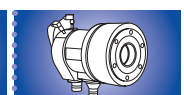

Page 225

- LARGE THROUGH HOLE
- 3 jaws

INCH serration

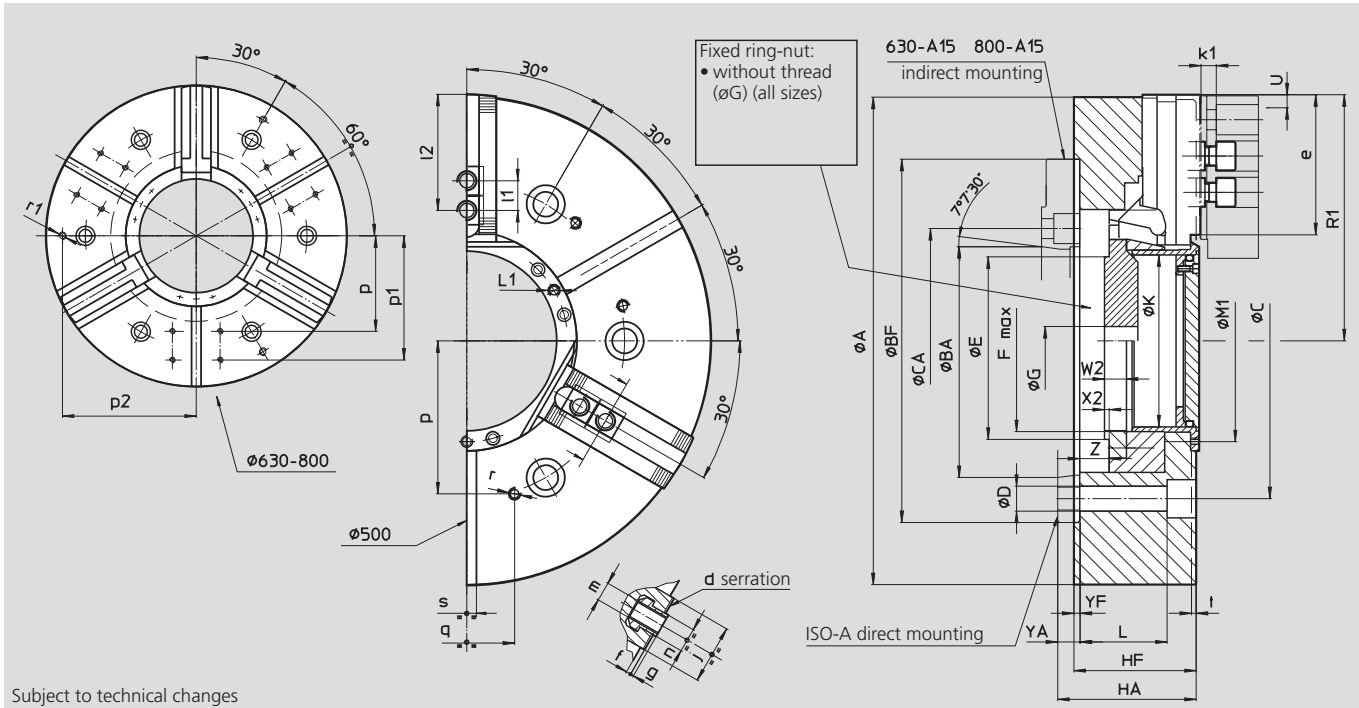

Subject to technical changes  
For more detailed information please ask for customer drawing

SMW-AUTOBLOK Type			BH-D 500		BH-D 630			BH-D 800		
Mounting			Z380	A15	Z520	A15	A20	Z520	A15	A20
	<b>A</b>	mm	510		630			800		
	<b>Bf/BA</b> H6	mm	380	285.775	520	285.775	412.775	520	285.775	412.775
	<b>C</b>	mm	330.2		463.6	-	463.6	463.6	-	463.6
	<b>CA</b>	mm	-	-	-	330.2	-	-	330.2	-
	<b>D</b>	mm	26		26			26		
	<b>E</b>	mm	206		260			260		
	<b>Fmax</b>	mm	M190 x 3 (*)		M250 x 3 (*)			M250 x 3 (*)		
	<b>G</b>	mm	30		30			30		
	<b>Hf/HA</b>	mm	128	145	150	184	169	150	184	169
	<b>K</b>	mm	180		230			230		
	<b>L</b>	mm	91		99			99		
	<b>L1</b>	mm	M8/9		M8/16			M8/16		
	<b>M1</b>	mm	211		270			270		
Chuck open	<b>R1</b>	mm	257.5		314			399		
Jaw stroke	<b>U</b>	mm	6.5		9			9		
	<b>W2</b>	mm	23		23			23		
	<b>X2</b>	mm	5		5			5		
	<b>Yf/YA</b>	mm	6	23	6	40	25	6	40	25
max./min.	<b>Z</b>	mm	31/0		34/0			34/0		
<b>BH-D</b> serration	<b>d</b>	inch	3/32" x 90°		3/32" x 90°			3/32" x 90°		
	<b>e</b>	mm	146.5		152			237		
	<b>f</b>	mm	5		10			10		
	<b>g</b>	mm	3.5		3.5			3.5		
	<b>j</b>	mm	62		62			62		
	<b>k1</b>	mm	16		16			16		
	<b>l1</b>	mm	38		38			38		
max./min.	<b>l2</b>	mm	121/53		127/53			212/53		
	<b>m</b>	mm	M20		M20			M20		
	<b>n</b> h8	mm	25.5		25.5			25.5		
	<b>p</b>	mm	160		200			200		
	<b>p1</b>	mm	-		260			260		
	<b>p2</b>	mm	-		280			280		
	<b>q</b>	mm	100		100			100		
	<b>r</b>	mm	M12/22		M12/22			M12/22		
	<b>r1</b>	mm	-		M16/28			M16/28		
	<b>s</b> H12	mm	20		20			20		
	<b>t</b>	mm	5		5			5		

(\*) max possible thread on blank ring-nut.