

SMW-AUTOBLOK

worldwide leader

in Steady Rests

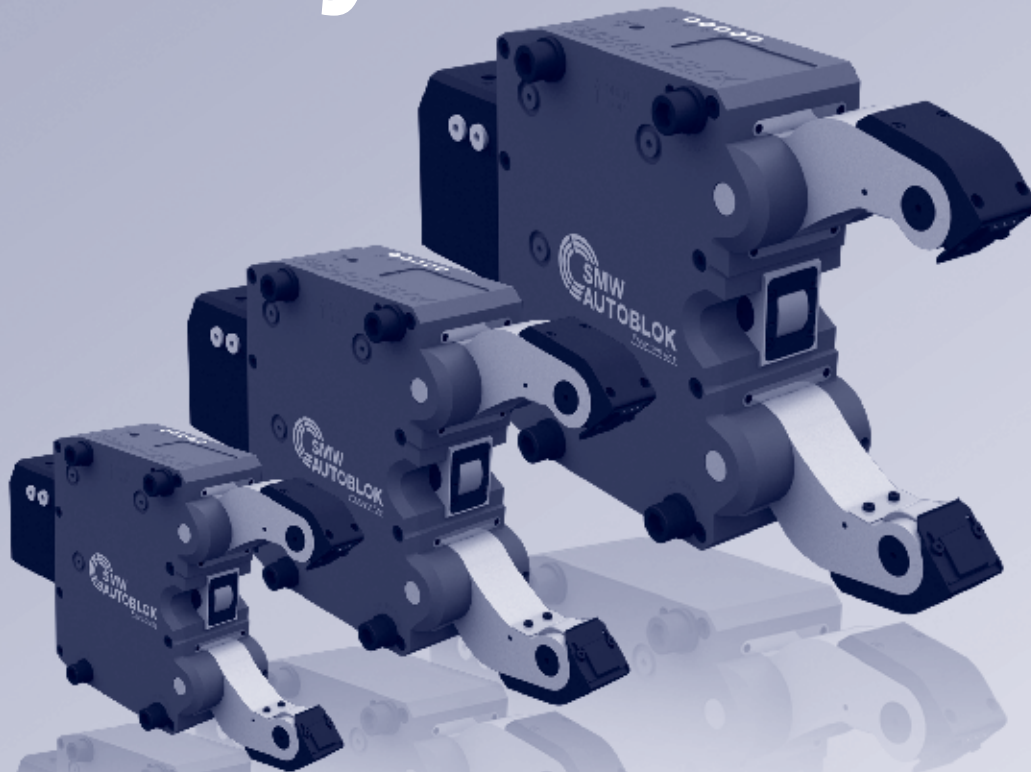

Fixed or travelling application

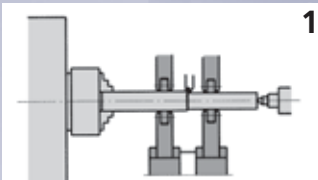

1

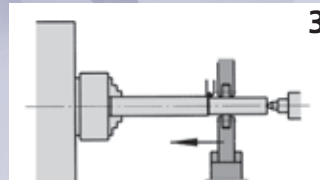

2

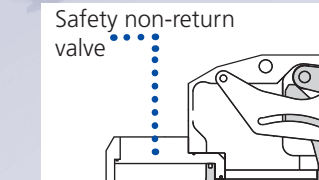

3

1. Tandem Steady Rest fixed
2. Steady Rest fixed for end machining
3. Steady Rest travelling

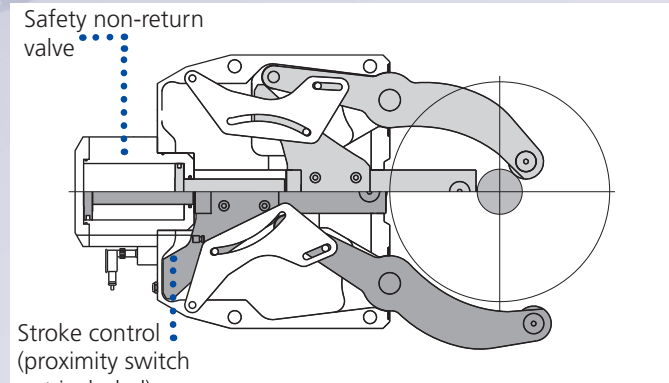

Safety non-return valve

Stroke control (proximity switch not included)

Features included in standard range

Steady Rest type	Standard Line		Premium Line			
	SLU-X, SLUA-X	SLU-B, SLUA-B	SR	SRA	K, KA	KLU
Steady Rest size	1 - 5.1	3 - 6	1 - 6	2 - 6	3 - 7.1	215 - 540
Sealed body	■		■	■	■	■
Safety valve	■	■	■	■	■	■
Stroke control (open position)	■	■	■	■	■	■
1 set swarf guard 3-piece	■	■				
1 set swarf guard with integrated coolant flush			■	■	■	■
1 set cylindrical rollers	■	■	■	■	■	■
Port for compressed air	■	■	■	■	■	■
Port for coolant through arms incl. chipguard			■	■	■	■

SLU-X[®] / SR[®] / K / KLU

SLU-X/SR/K/KLU
large clamping
range

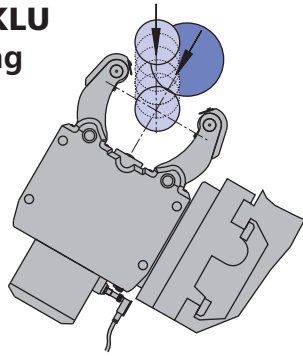

SLUA-X/SRA
additional
pivoting upper
arm
for automatic
vertical loading
(worldwide
patented)

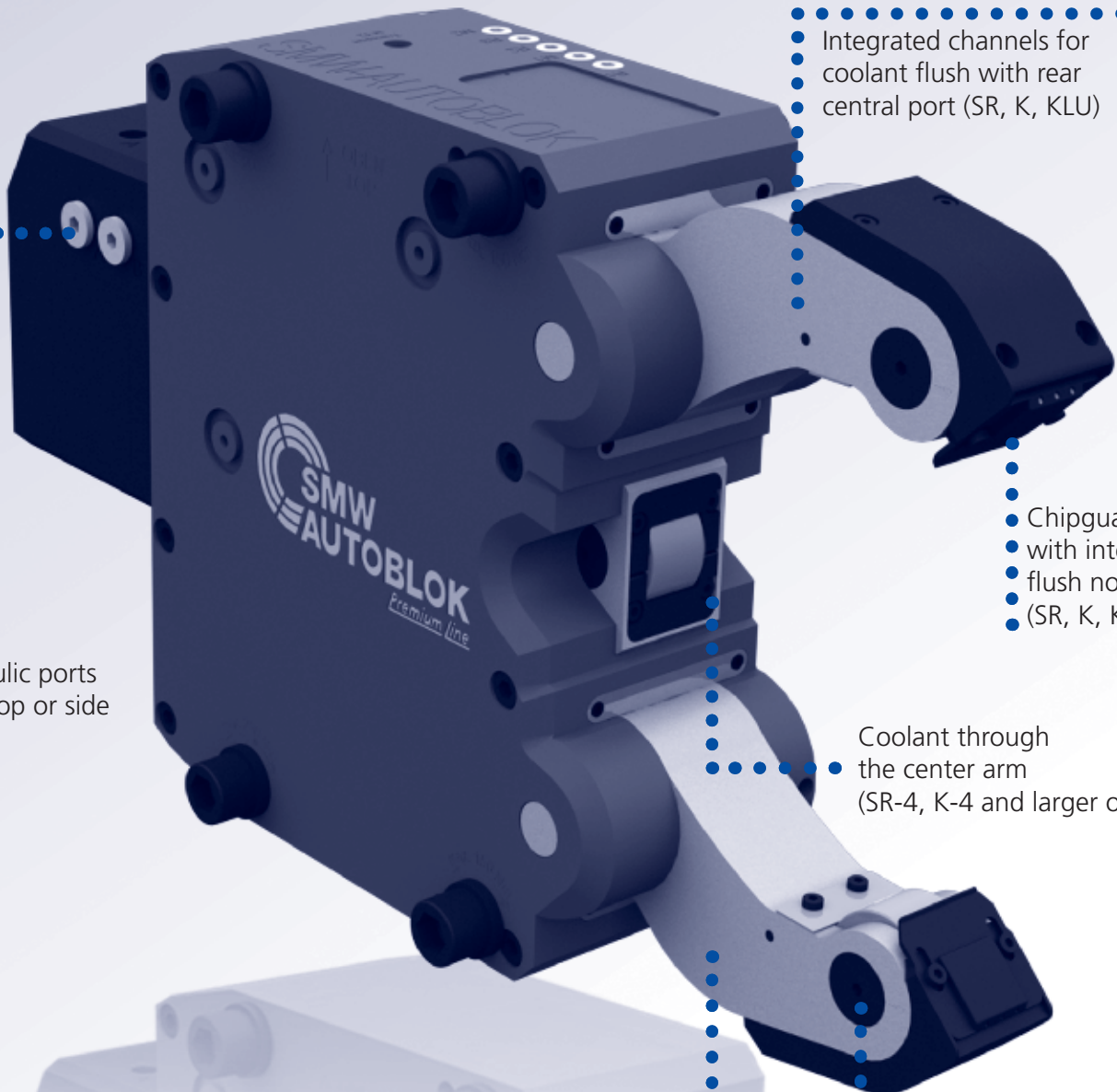
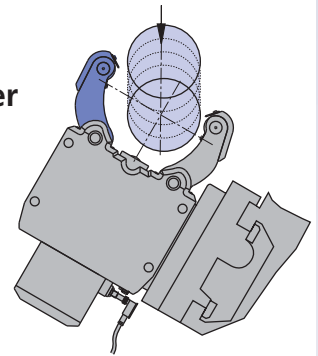

Hydraulic ports
from top or side

Integrated channels for
coolant flush with rear
central port (SR, K, KLU)

Chipguard
with integrated
flush nozzle
(SR, K, KLU)

Coolant through
the center arm
(SR-4, K-4 and larger only)

**Patented mechanism
for opening the arms of the
Steady Rest without
springs and free from wear.
(worldwide patented)**

Arms and centerpiece
hardened
(SLU-X, SR, K, KLU)

Easy change of rollers
without loose parts

SLU-X®
SLU-B

SLUA®-X
SLUA®-B

SR®
SRA

KLU
K

Equipment

Option of manual lubrication (M)

- Low cost solution for medium working conditions and low build up of swarf.
- The lubrication points and rollers are supplied with lubrication grease via the grease nipples and the grease gun.
- Lubrication intervals depending on the working conditions normally every 4 to 8 operating hours.
- Grease: KPE 2R-20 DIN 51502

Manual lubrication (M)

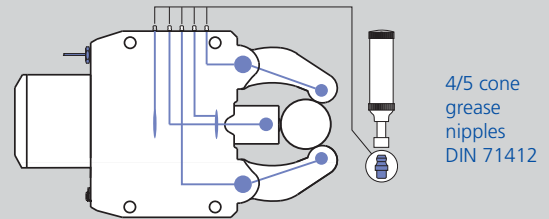

Option of central oil lubrication (Z)

- For heavy working conditions and high build up of swarf
- For travelling Steady Rest applications.
- The use of our separate complete lubrication unit with timer control is recommended.
- Lubricating intervals 5 - 20 min
- Min./max. operating pressure 10 to 45 bar.
- Oil: Viscosity of 46 mm²/s (viscosity class ISO)

Central lubrication (Z)

Lubrication unit oil
Id. No. 088707

Centralized lubrication G 1/8"

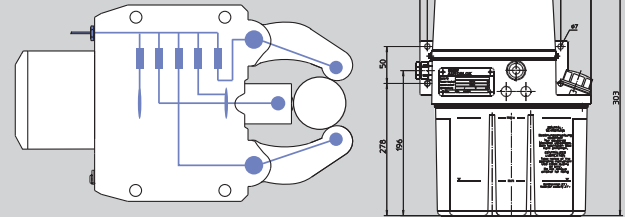

Option of central lubrication oil + air (OLD)

- For heaviest cutting conditions with high built up of swarf, dust or coolant.
- The SMW-AUTOBLOK oil + air unit for lubrication with built-in timer control is mandatory.
- This unit injects oil for lubrication into the air hose in adjustable intervals (2 -12 min.).
- The permanent air flow (min. 3 bar) feeds the oil to the rollers and keeps them clean.
- Oil: Viscosity of 46 mm²/s (viscosity class ISO)

Oil + air lubrication (OLD)

Lubrication unit oil + air
Id. No. 088708

Centralized lubrication G 1/8"

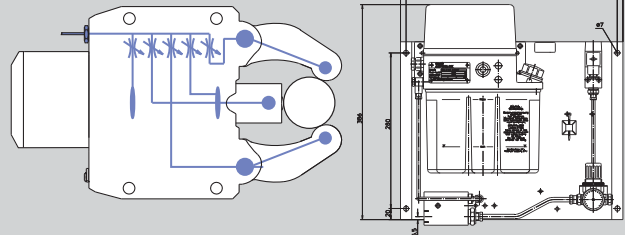

Option of central grease lubrication (F)

- For machines with central grease lubrication
- For application and intervals please follow the instruction of the machine maker.
- Min./max. operating pressure 30 to 45 bar.
- Grease: NLGI class 0 or 1

Central grease lubrication (F)

Centralized lubrication G 1/8"

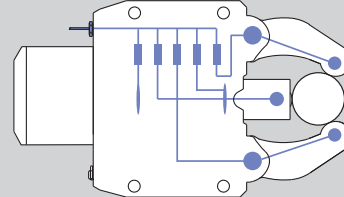

Option of rollers

- SMW-AUTOBLOK rollers (precision class P05) specially developed for our Steady Rests.
- Special sealing ensures highest precision and service life.
- Standard equipment: 1 set of cylindrical rollers.
- Option: Spherical rollers (for travelling Steady Rests), synthetic material rollers, carbide rollers.

Original
SMW-AUTOBLOK
roller

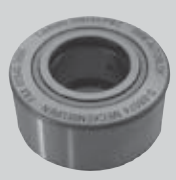

cylindrical

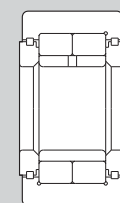

spherical

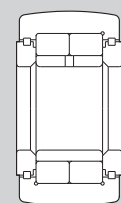

narrow



Rollers (all types)

- Rollers steel (standard): Surface of workpiece not hardened

Available optional materials:

- Rollers synthetic material: Surface of workpiece polished or chrome plated
- Rollers carbide: Surface of workpiece hardened

Rollers
steel

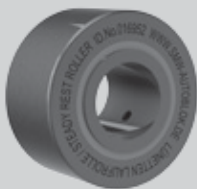

Rollers synthetic
material

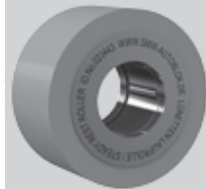

Rollers
carbide

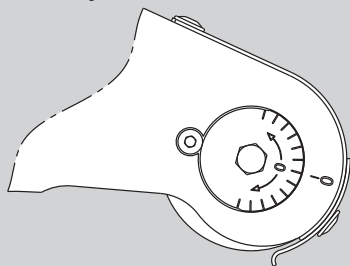

Eccentric fine adjustment**Option fine adjustment of center line**

- Eccentric roller pins on the two Steady Rest arms allow a quick fine adjustment of the center line.
- This avoids to unlock and adjust the entire Steady Rest on the bracket for small adjusting movements.
- Adjustment of open steady rest only!

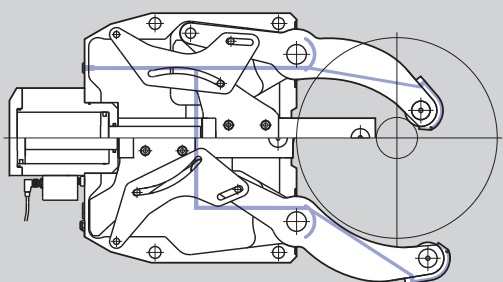
Coolant/air feed**Coolant/air feed (SR/K/KLU only)**

- Built-in channels to feed coolant or air from a central connecting port to the Steady Rest arms.
- Basic equipment for SR/K/KLU steady rests
- From size SR-4 / K4 and larger with coolant through the center arm

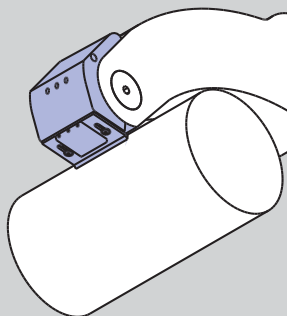
Chipguard coolant/air**Patented coolant/air chipguard with integrated flush nozzles (SR/K/KLU only)**

- Keeps roller clamping area free from chips
- The patented double flush nozzles keep front and rear of the wiper area clean.

Only for steady rests with coolant / air feed.**Benefit:**

- Constant centering accuracy
- No damage of workpiece and rollers caused by chips/swarf
- Less roller consumption = less costs

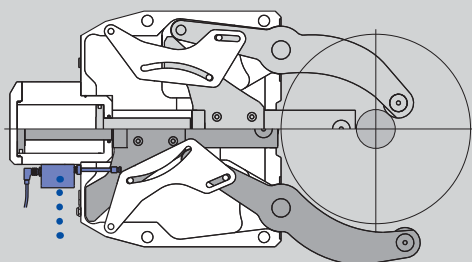
**SCU-A/SCU-V
diameter measuring system****SCU-A/SCU-V****Option linear diameter measuring system
SCU-A/SCU-V**

- The position of the clamping arms is monitored by the linear measuring system SCU-A/SCU-V.
- Avoids collision with workpieces, turret, loader etc.
- Reduced cycle time due to position controlled opening of the arms to the requested opening only.
- SCU-A: In: 24 V Out: 4 – 20 mA
- SCU-V: In: 24 V Out: 0 – 10 V

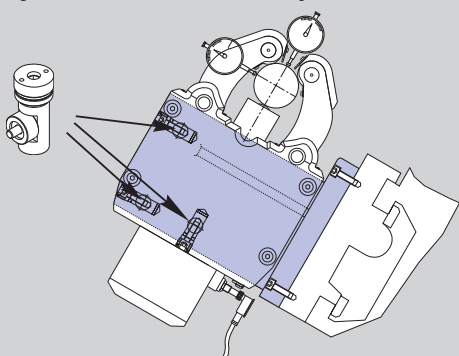
Steady Rest bracket with adjustment device**Steady Rest bracket**

- A perfect bracket is very important for the function/precision of the Steady Rest.
- Fast and easy adjustment can be done with the SMW-AUTOBLOK adjustment device integrated into the bracket.
- SMW-AUTOBLOK supplies the correct bracket for all applications as a turnkey solution.

Additional pivoting upper arm for vertical loading

- Compact design, Sealed body
- Integrated coolant flush
- Double guided center arm to carry heavy loads
- Excenter fine adjustment on the outer arms

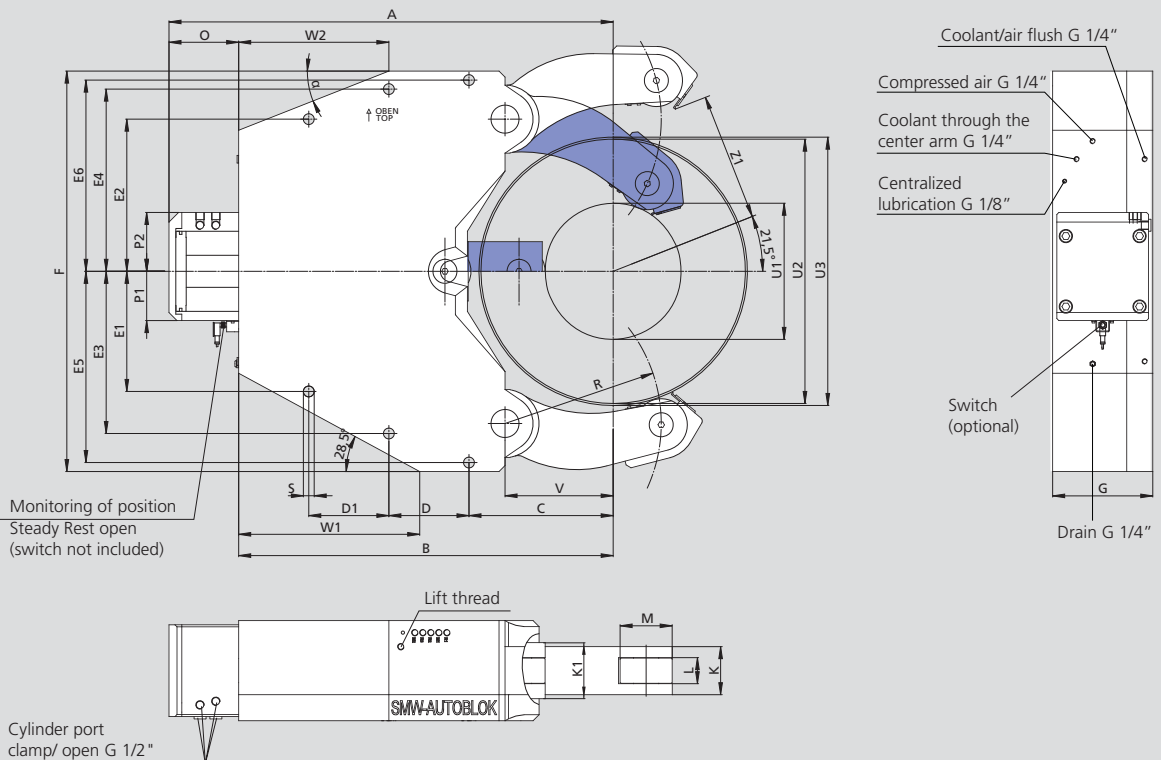

Subject to technical changes
For more detailed information please ask for customer drawing

SMW-AUTOBLOK Type		KA 7	KA 7.1
Centering range with coolant chip guard	U1	340	650
	U2	660	910
Max. axial clearing diameter	U3	670	916
Vertical loading with chip guard	Z1	330.7	456
	A	1109	1165
	B	935	1015
	C	360	450
	D	210	220
	D1	210	220
	E1	300	240
	E2	380	320
	E3	405	365
	E4	455	415
	E5	477.5	477.5
	E6	477.5	477.5
	F	1000	1000
	G	250	250
Width of outer arms	K	120	120
Width of center arm	K1	140	140
	L	65	65
	M	130	130
	O	174	150
	P1	123	123
	P2	147	147
	R	390	530
	S	27	27
	V	270	390
	W1	452	522
	W2	375	485
	α	21.5°	22°
Piston area	cm ²	314	314
Operating pressure max.	bar	80	80
Max. clamping force/roller	daN	8500	8500
Centering accuracy within the whole range	mm	0.08	0.08
Repeatability accuracy	mm	0.03	0.03
Max. roller surface speed	m/min	425	425
Weight approx.	kg	1050	1050







- Ordering review
- Accessories and wearing parts

KA Steady Rest with stroke control Steady Rest open via proximity switch (without proximity switch)

Steady Rest size		KA 7	KA 7.1
KA-M manual lubrication	Id. No.	222901	222951
KA-Z central lubrication	Id. No.	222900	222950
KA-OLD central lubrication oil + air	Id. No.	222902	222952
KA-F central grease lubrication	Id. No.	222903	222953

Type KA

◆ denotes wearing parts, recommended stock items

Steady Rest size		KA 7	KA 7.1
Compact lubrication system for oil pressure lubrication Container 2.7 l, 220 V *,**		088707	088707
Compact lubrication system for oil + air lubrication Container 2.7 l, 220 V *,**		088708	088708
Inductive limit switch		087926	087926
Swarf guard coolant/air with wiper		222944	222944
Wiper for swarf guard coolant/air	 ◆	222994	222994
Roller stripper for middle piece	 ◆	202358	202358
Rollers, cylindrical design	 ◆	028525	028525

* When placing an order, please advise voltage

** On request 110 V available

SLU-X®
SLU-B

SLUA®-X
SLUA®-B

SR®
SRA

KLU
K

Our additional program:
■ Special Steady Rests
■ Turret Steady Rests
■ Crankshaft Steady Rests
■ Grinding Steady Rests

Steady Rests clamping big crankshaft

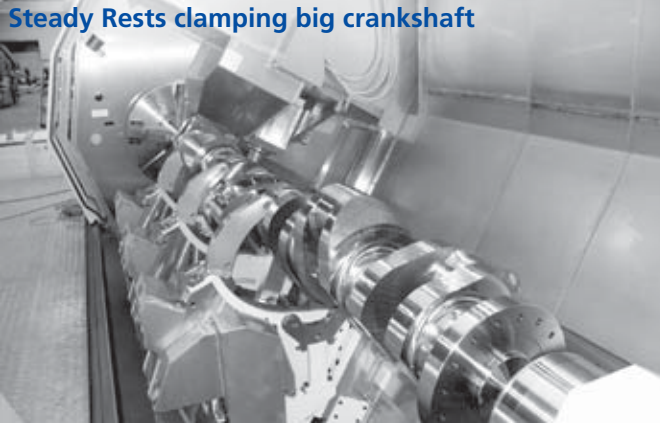

Steady Rests clamping big crankshaft



Steady Rest clamping turbine shaft

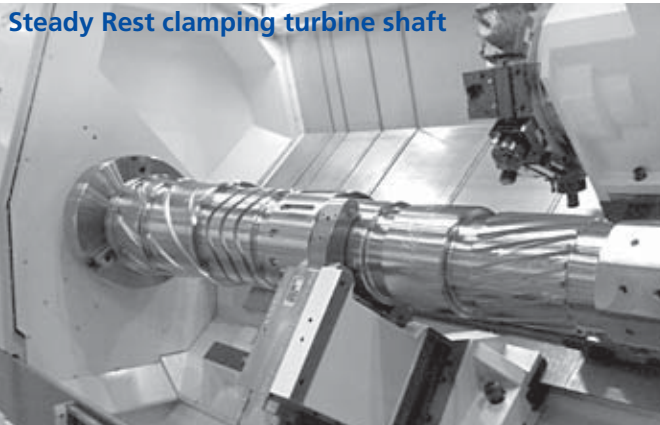

Steady Rest clamping special shaft



Steady Rest clamping train axle



Steady Rest with diamond pads clamping input shaft in hard turning/grinding operation



Turret Steady Rest

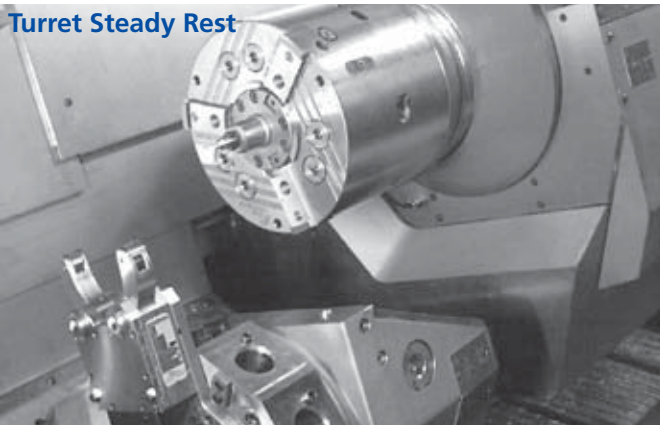

Steady Rest clamping aircraft shaft

